

PLY  COLLECTION

THE MOST
BEAUTIFUL
WOODEN
CHAIRS





ABOUT US

We have chosen to work with wood – natural, beautiful and alive material. Combining unique technology of moulding plywood with modern design that will delight even the most demanding eye, PLYCOLLECTION is offering selected chair collection for public and private interiors. Our chairs are for those who love wood, respect nature and want to bring this pure beauty into their everyday life.

Discover our elegant, light and comfortable chairs!

WhyUs
www.whyus.nl

FRAME



DESIGN
Komplot Design, Denmark

APPLICATION
museums, libraries, banks,
halls, waiting areas,
meeting rooms, restaurants

MATERIAL
Form pressed plywood
with solid wood insert

FINISHES
birch, oak, walnut, zebrano,
wenge, white and black
laminare

OPTIONS
upholstered seat pad,
linking

stackable sideways
up to 6 pieces

TESTS
DIN EN 1728, DIN EN 13 761





FRAME IS A MONO-BLOCK CHAIR, MOULDED IN ONE PIECE OF PLYWOOD WITH VARIABLE THICKNESS AND SOLID WOOD INSERT. THE WHOLE CHAIR IS PRESSED IN ONE SINGLE PROCESS. UNUSUAL SIDEWAYS STACKING IDEA ALLOWS THE CHAIR TO STACK AND KEEP A SIMPLE, CLEAR, ALMOST CLASSIC FORM – WELL PROPORTIONED AND ERGONOMIC. THE SQUARE CUT IN THE BACKREST GIVES THE FEELING OF TRANSPARENCY. PURE AND AESTHETIC DESIGN OF FRAME OFFERS POSITIVE EXPERIENCES FOR ARCHITECTS AND CUSTOMERS.

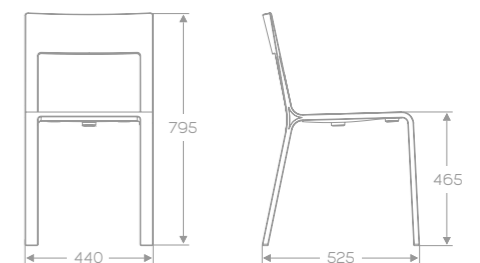



CLASSIC
ARTLESS
FUNCTIONAL
ARCHITECTURAL
PURE





STRONG
OUTSTANDING
ASCETIC
UNUSUAL
STABLE



FLOW

DESIGN
Jakob Berg, Denmark

APPLICATION
hotels, restaurants,
museums, libraries,
churches, halls, waiting
areas, meeting rooms

MATERIAL
form pressed plywood

FINISHES
birch, oak, walnut, zebrano,
wenge

OPTIONS
upholstered seat pad,
linking

stackable up to 10 pieces

TESTS
DIN EN 1728, DIN EN 13 761

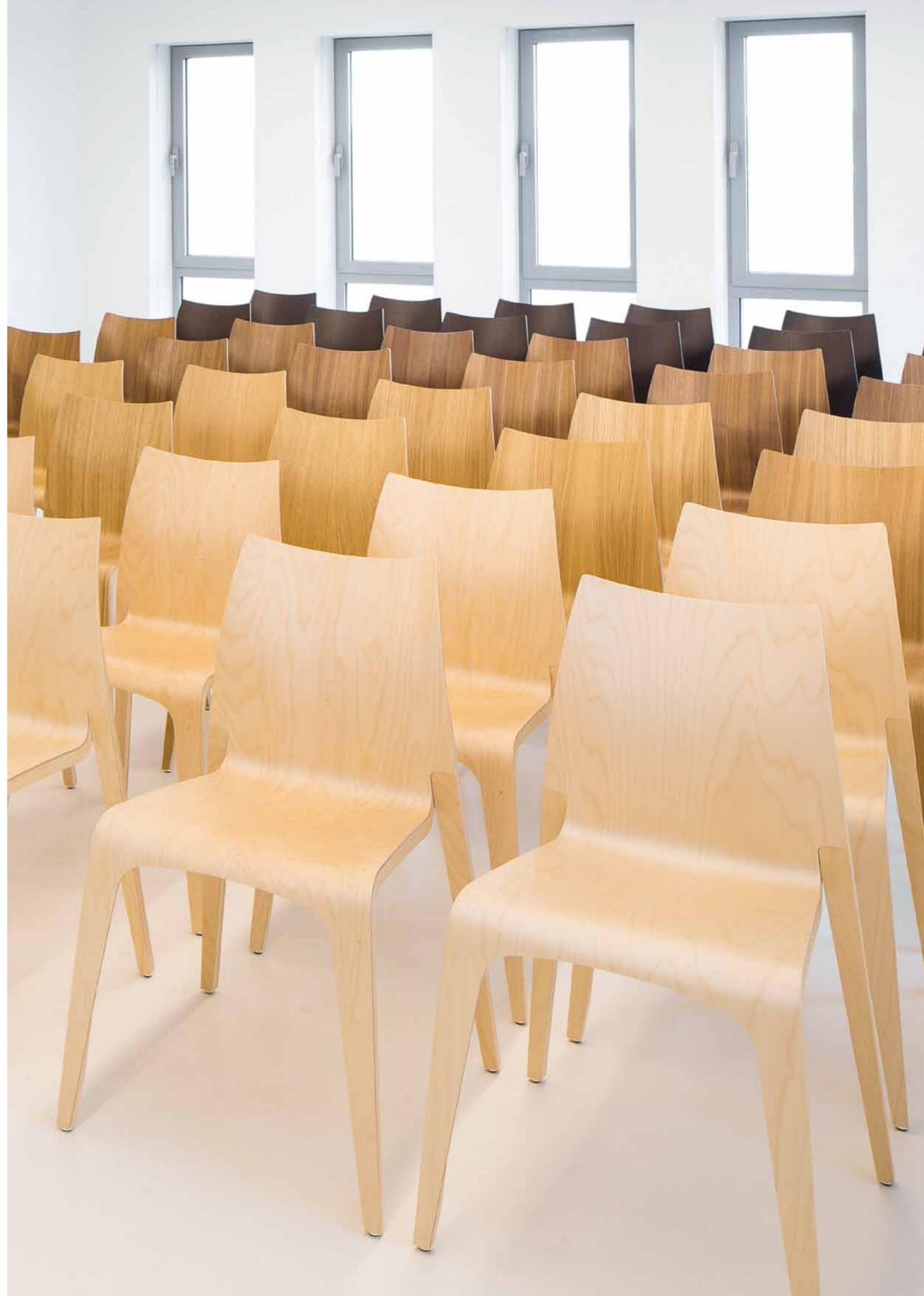







ELEGANT
BEAUTIFUL
COMFORTABLE
GRACEFUL
DIFFERENT

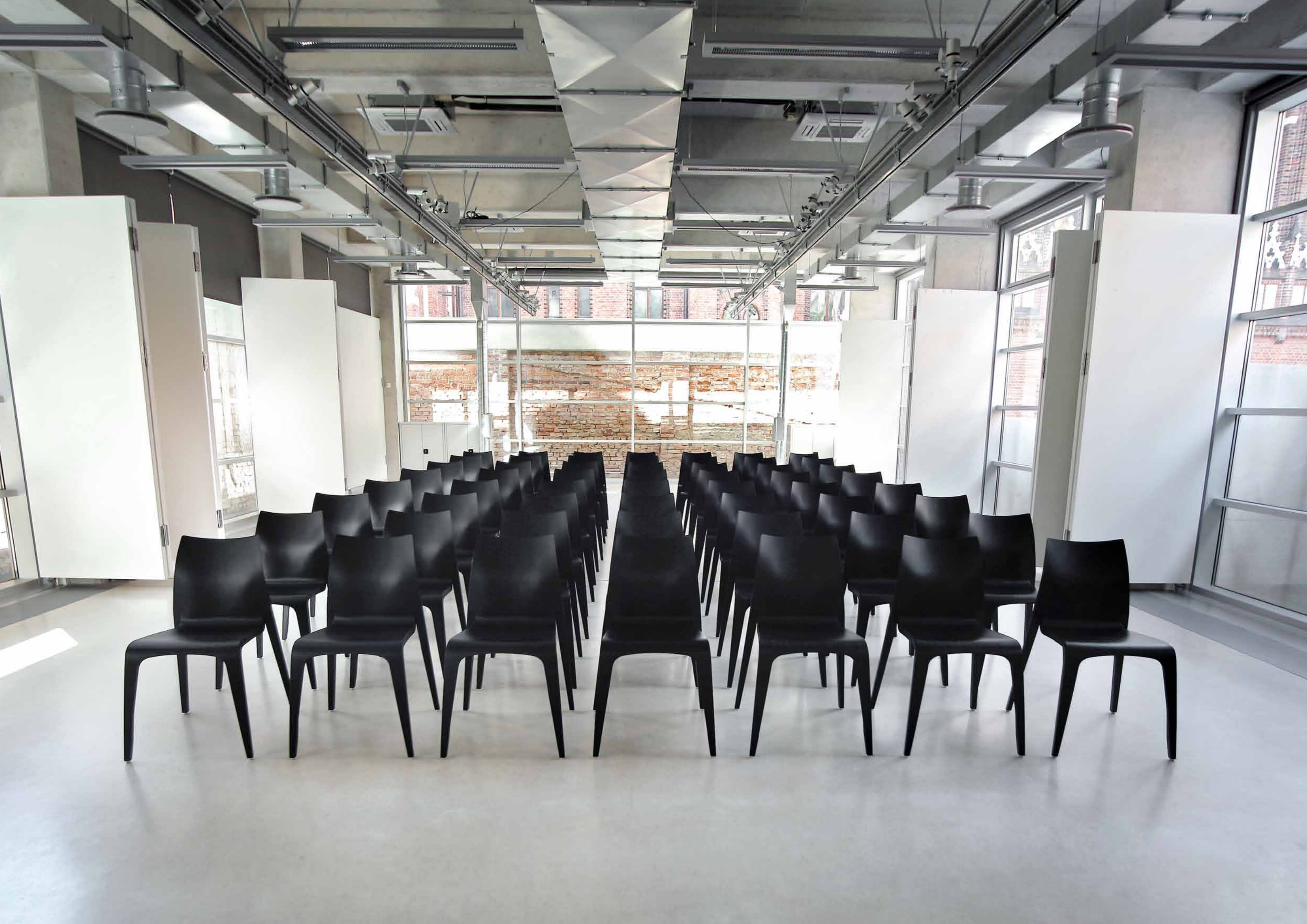



EVERY DETAIL OF FLOW CHAIR HAS BEEN DESIGNED WITH THE GREATEST LOVE. WE THINK FLOW IS ONE OF THE MOST BEAUTIFUL WOODEN CHAIRS CREATED DURING THE LAST 100 YEARS. IT IS LIGHT AND STACKABLE MULTI-PURPOSE CHAIR THAT COMBINES THE BEAUTY OF PLYWOOD WITH INNOVATIVE MOULDING TECHNIQUE PUTTING PRECISION AND DETAILS IN FOCUS. IT'S CLEAN LOOK, TIMELESS DESIGN AND EXCELLENT SITTING COMFORT MAKE IT SUITABLE FOR THE WIDEST SPECTRUM OF PUBLIC AND PRIVATE INTERIORS. IT JUST LOOKS BEAUTIFUL EVERYWHERE.

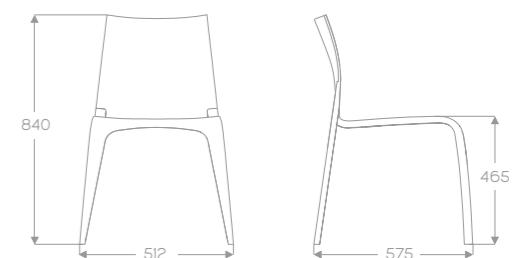

ZESTY

DESIGN
o4i Designstudio, Sweden

APPLICATION
conference halls, meeting
and waiting areas

MATERIAL
form pressed plywood

FINISHES
birch, oak, walnut, zebrano,
wenge, pigmented lacquer
any RAL colour

OPTIONS
seat and back upholstery,
linking

stackable up to 15 pieces

TESTS
DIN EN 1728, DIN EN 16 139

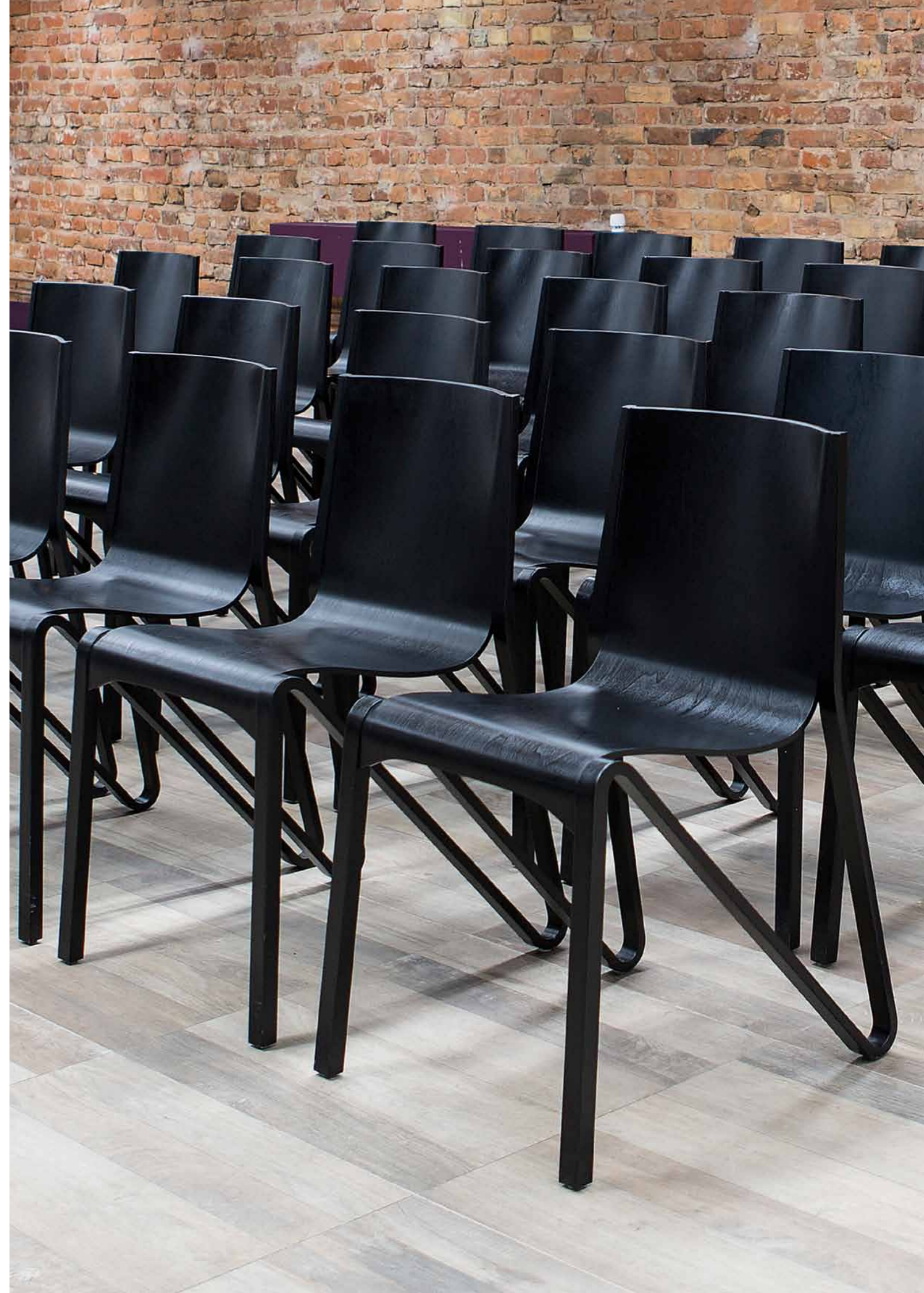





ОЗ БАЯНЫНДЫ ЖАЗ
O'ZINGIZNING NIKOYANGIZNI YARATING
СОЗДАЙ СВОЮ ИСТОРИЮ
CREEAZA-TI POVESTEAA LOO OMA LUGU
СТВОРИ СВОЮ ИСТОРИЮ
创作你的故事 STWÓRZ SWOJA HISTORIĘ CREA LA TUA STORIA
SCHREIB DEINE GESCHICHTE!
CREËER JE EIGEN VERHAAL
SKAP DIN HISTORIE
CREE SAU APROPIA HISTORIA
СТВОРИ СВОЮ ИСТОРИЮ
CREATE YOUR STORY
KENDI MASALINI KUR
VEIDO SAVU STĀSTU
SAKUR IK SAVO ISTORIJA
LOO OMA LUGU CREA TU PROPRIA HISTORIA
СОЗДАЙ СВОЮ ИСТОРИЮ
LUO TARINASI
O'ZINGIZNING NIKOYANGIZNI YARA
MAAK JOU EIE STORIE
СТВАРЫ СВАЮ ГІСТОРЫЮ
ECRIRE TON HISTOIRE
STU
SCHREIB DEINE
A 创作





LIGHT
SLIM
SCULPTURAL
CONTEMPORARY
NATURAL





DURABLE
BRIGHT
COLORFUL
ELEGANT
ZESTY







ORGANIC FORMS AND LIGHTNESS OF THE CHAIR IN COMBINATION WITH EXTREMELY STRONG PLYWOOD TECHNOLOGY MAKE ZESTY SUITABLE FOR ANY PUBLIC OR PRIVATE ENVIRONMENT.

WITH A MINIMUM OF MATERIAL AND A MAXIMUM OF COMFORT AND STYLE IT BRINGS OUT THE BEST OF MOULDED PLYWOOD. ZESTY IS ASSEMBLED BY 3 PARTS ONLY AND WEIGHS AS LITTLE AS 3 KG. THE CHARACTERISTIC LEG FRAME AND A SLENDER ZESTY PROFILE WILL MAKE THE INTERIORS OUTSTANDING AND REMARKABLE.

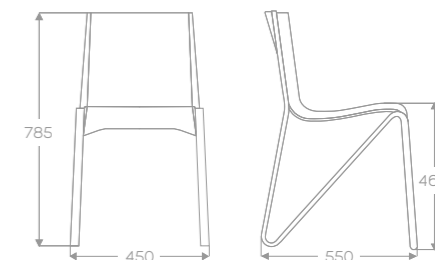

CHAT



DESIGN
Jakob Wagner, Denmark

APPLICATION
restaurants, offices,
corporate meeting rooms,
banks

MATERIAL
Form pressed plywood,
chromed or powder
coated frame

FINISHES
birch, oak, walnut, zebrano,
wenge

OPTIONS
4-leg frame,
swivel frame,
upholstered seat pad

TESTS
DIN EN 1728, DIN EN 13 761





TIMELESS
OUTSTANDING
PLAYFUL
STRONG
CHAT

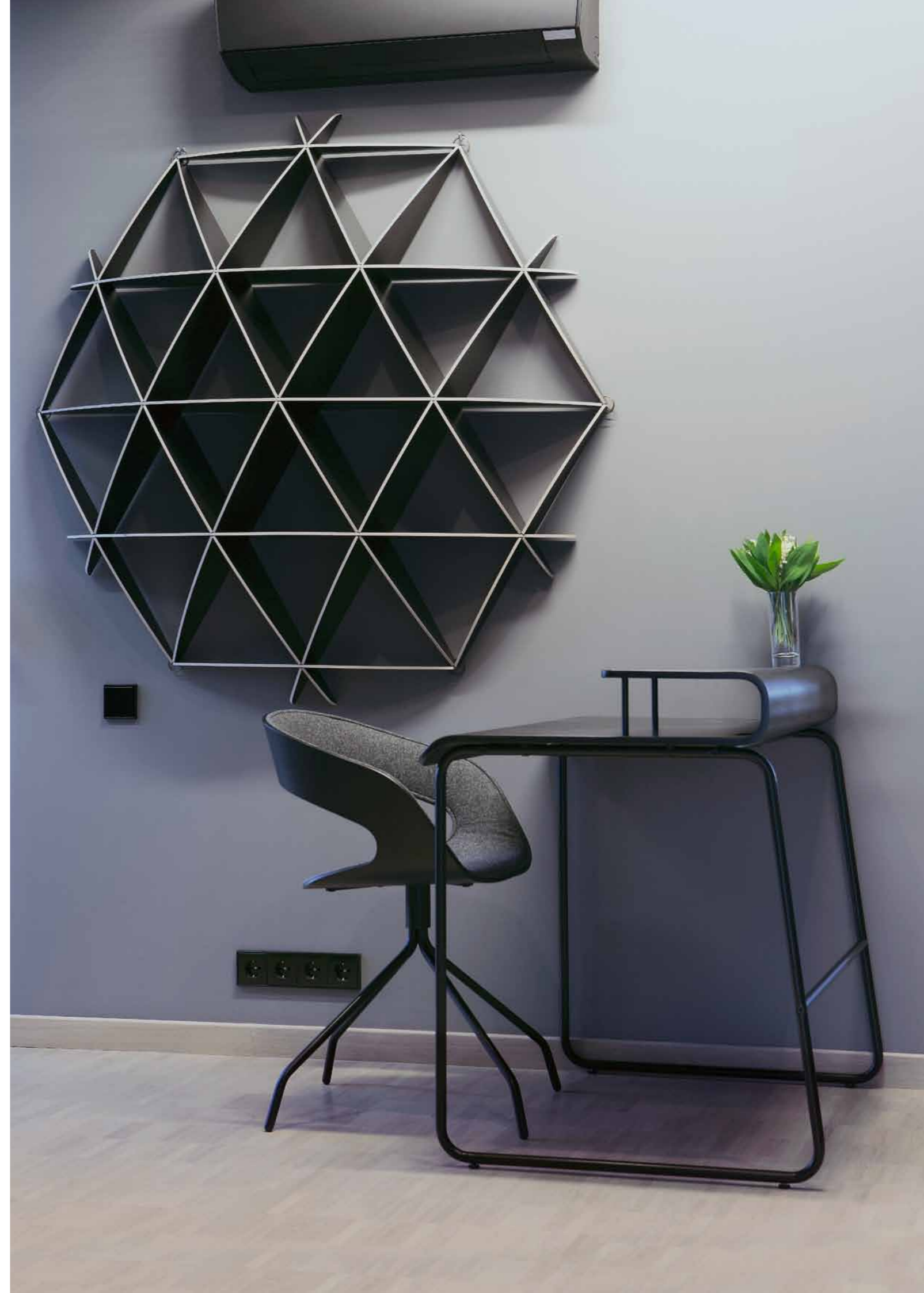



FOLDED ONE PIECE OF PLYWOOD WITH DISCREET JOINING IN THE MIDDLE OF SEAT CREATES FAMILIAR ROUND SHAPE OF THE CHAIR. IT IS UNIQUE IN TECHNOLOGY AND VARIETY OF GREAT SITTING COMFORT. THAT WILL ADD THE LAST STRAW OF ELEGANCE TO THE INTERIOR AND WILL PROVIDE YOU WITH POSITIVE EMOTIONS WHILE SITTING OR JUST LOOKING AT IT. IT MAY BE CONSIDERED FOR CORPORATE MEETING ROOMS, HOSPITALITY AND RESIDENTIAL ENVIRONMENTS.

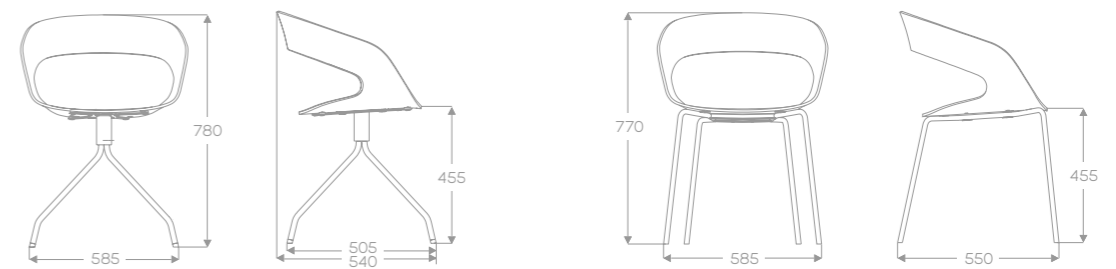

PYT FAMILY

PYT bar stool
PYT chair
PYTHON chair

DESIGN
Komplot Design, Denmark

APPLICATION
cafeterias, restaurants,
Internet cafes, receptions,
schools, universities

MATERIAL
form pressed plywood,
chromed or powder
coated frame

FINISHES
birch, oak, walnut, zebrano,
wenge, white and black
laminated

OPTIONS
upholstered seat pad

stackable up to 8 pieces

TESTS
DIN EN 1728, DIN EN 13 761







STRONG
STACKABLE
UNUSUAL
CONTRASTING
STABLE







“THE 2 ICONS OF 20TH CENTURY’S DANISH FURNITURE DESIGN: THE “VALET” CHAIR OF H. WEGNER AND THE “ANT” CHAIR OF A. JACOBSEN. WHAT WILL HAPPEN IF WE CROSSBREED THEM?” THIS QUESTION KOMPLOTT ASKED THEMSELVES AND RELATED IT TO COMMON SITUATION WHEN VISITING A RESTAURANT, WE MISS A GOOD CHAIR-BACK ON WHICH TO HANG OUR JACKET. WITH THE MAIN FOCUS ON FUNCTIONALITY, A SPECIAL CONSTRUCTION OF THE PLYWOOD SHELL WITH ENLARGED THICKNESS IN THE CURVE, MAKES THE COLLECTION EXTREMELY STRONG FOR USE IN ALL KIND OF PUBLIC ENVIRONMENTS, CANTEENS, CAFES, HOTELS, RECEPTION AREAS. SPECIAL ADVANTAGE – STACKABLE BAR STOOL PYT.

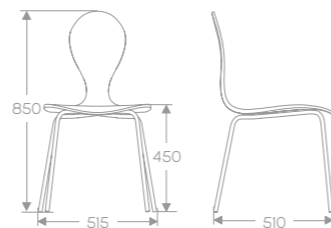
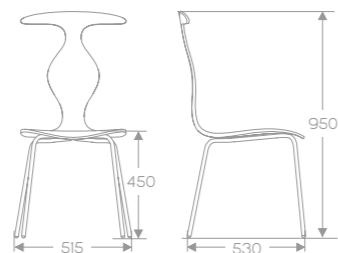
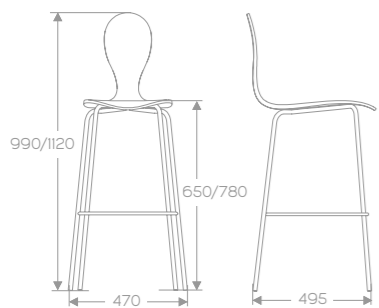

FINESTRA

DESIGN
Komplot Design, Denmark

APPLICATION
halls, meeting and waiting
areas, banks

MATERIAL
form pressed plywood,
solid rod frame, chrome or
powder coated

FINISHES
birch, oak, walnut, zebrano,
wenge, white and black
lamine

OPTIONS
upholstered seat pad

stackable up to 8 pieces

TESTS
DIN EN 1728, DIN EN 13 761





FINESTRA IS A MULTI-PURPOSE CHAIR WITH A MOULDED PLYWOOD SHELL IN VARIABLE THICKNESS THAT ALLOWS WINDOW-LIKE CUTOUTS IN THE BACK. THE GEOMETRIC CLEARNESS OF FINESTRA FRIENDLY FITS IN ANY ENVIRONMENT. THE BACK OF A CHAIR, MINIMIZED TO THE SIMPLE FRAME, PROVIDES TRANSPARENCY IN THE ROOM. FINESTRA HAS WELL STACKING AND LINKING FEATURES.

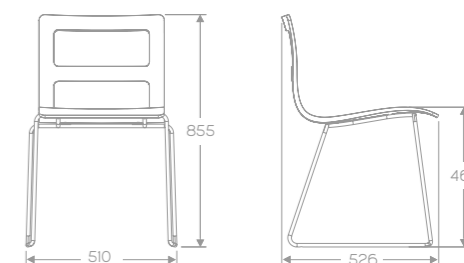

REFERENCES

AUSTRALIA KEW Heights Sports Club Melbourne – Ice Cube Restaurant in Sydney – Hotel Mantra South Bank Brisbane
AUSTRIA Hotel Berghof – Technische Universität Graz – Rheuma Sonderkrankenanstalt Bad Gastein – Allgemeines Krankenhaus Linz – Gesundheitsresort Lebensquell Bad Zell – Christophorus Reisebüros
BELGIUM Decospan Tree house – Glaxo Smith Kline – Mijn Restaurant TV
CZECH REPUBLIC Amenity Resort Špindlerův Mlýn – Cafes at OMW filling stations – City Theatre Kolin
FINLAND Laurea University of applied sciences – Lehmonkärki
FRANCE ORGA SYSTEM in Villejust – Hotel Mercure Toulouse Compans Caffarelli
GERMANY Klinik Am Weißenhof, Weinsberg – Staatstheater am Gärtnerplatz – InterCityHotel Hamburg Altona – Hockey Club Mannheim – Berlin art’otel, Kū’damm – Restaurant Intermezzo in Ludwigsburg – Christengemeinschaft Köln Ost – Evangelische Pfingstkirchengemeinde in Frankfurt/M, Griesheim – Messe München International – Mainfränkisches Museum in Würzburg – Technische Hochschule Wildau – NAC fine bio-food restaurant in Hamburg – SAP in Walldorf – Kirche Detmold – Graf Recke-Stiftung – Agentur für Arbeit in Stuttgart – Ärztezentrum Peine – Atmando Holistic Center in Frankfurt/M – Bildungshaus Bruder Klaus in Mosbach – Hessisches Baumanagement in Frankfurt/M – Karlsruher Club – Literaturmuseum Marbach – Referenzzentrum Mammographie in Berlin – SEW Eurodrive GmbH & Co in Bruchsal – Sozialdienst Katholischer Frauen – Konvikt Rottweil – Konvikt St. Josef Ehingen
IRELAND Havas Dublin – Lemonjelly
HOLLAND Philips – ARISTO Accomodaties Amsterdam
HONGKONG Blueprint 2.0 coworking space
LATVIA Nordic Club House – RIGA airport – ARENA Riga Hockey Hall – DSV Transport Latvia – Design Guest House Xcelsus – Fashion store Bergs – Emils Gustavs Chocolate Cafe – Ford Center – Guest House Ribbes Vejdzirnavas – Jurmala City Museum – Mediterranean Restaurant Riviera – Guest House Nitaures Dzirnavas – Ministry of Defence of the Republic of Latvia – Ministry of Transport of the Republic of Latvia – Restaurant Velvets – SEB Banka – Student corporation Fraternitas Metropolitana – Tourism Agency Your Run – Student Corporation Lettonija – Jazeps Vitols Latvian Academy of Music
LUXEMBOURG University of Luxembourg
SCANDINAVIA Östersunds Sporthall, Sweden – Tiger office canteen, Denmark – Haldum Hinnerup Skole, Denmark – Fisksättra Kyrka in Nacka, Sweden – Molde Kirkelige Fellesrad in Trondheim – Nansensenteret in Bergen – University of Bergen, Norway – Sohojllandet in Denmark – The Embassy of Latvia, Sweden
SWITZERLAND Starbucks
USA The William Wale hotel – Rubin Museum of Art, New York – Noelle, Nashville, a Tribute Portfolio Hotel – Bigelow Chapel, United Theological Seminary in New Brighton, Minnesota – The Embassy of Latvia in USA, Washington – Goldman Sachs – Coastal Carolina Movers in Wilmington

WhyUs
www.whyus.nl